

Production Size Specification

TRICORP

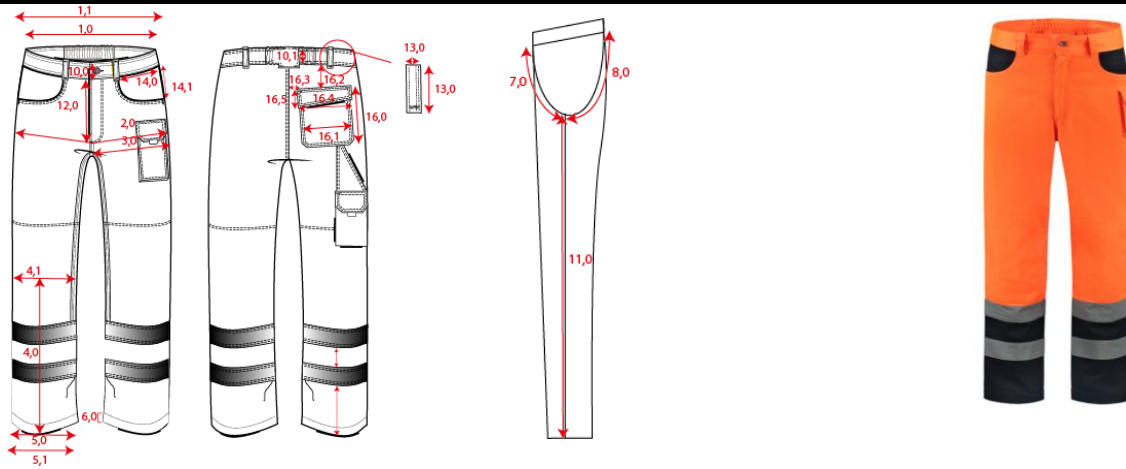

STYLE NO	503002
STYLE DESCRIPTION	Werkbroek ISO20471 Bicolor
FIT	Pants
GENDER	Unisex
DATE	20-1-2022
VERSION	V1

Sketch is for how to measure NOT for style

	42	44	46	48	50	52	54	56	58	60	62	64	66	Tol				AQM
Tricorp total body length	179	180	181	182	183	184	185	186	187	188	189	190	190					
1,0 1/2 Waist relaxed	35	37.5	40	42.5	45	47.5	50	52.5	55	57.5	61.5	65.5	69.5	1,0				X
2,0 1/2 Hip (under zip)	45	47.5	50	52.5	55	57.5	60	62.5	65	67.5	71.5	75.5	79.5	1,0				X
11,0 Inseam, long	83	83	83	83	83	83	83	83	83	83	83	83	83	0,5				X
Distance stripes from bottom up front	15	15	15	15	15	15	15	15	15	15	15	15	15	0,3				X
Distance stripes from bottom up back	15	15	15	15	15	15	15	15	15	15	15	15	15	0,3				X
Distance between stripping	6	6	6	6	6	6	6	6	6	6	6	6	6	0,3				X
Stripping height	6	6	6	6	6	6	6	6	6	6	6	6	6					X